

金属电缆 P 型防水接头

P Series Cable Gland

主体材质：黄铜镀镍

Body Material: Nickel-plated brass

温度：-40°C~+100°C，短时间 120°C

Temperature range: -40°C ~ +100°C, short-term to 120°C

防护等级：IP68(使用 O 型圈的情况下)

Protection Degree: IP68(Using O-sealing)

密封圈材质：尼龙 66 和丁晴橡胶

Sealing Material: Nylon 66 and NBR

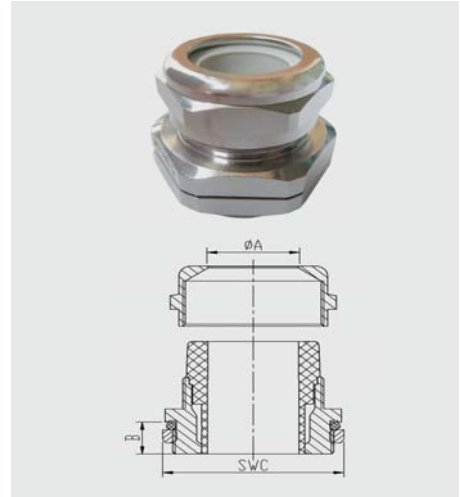

M 螺纹

螺纹 Thread	型号 Part no.	卡口范围 (mm) Clamping range	螺纹长度 (mm) Thread length	扳手尺寸 (mm) SW1XE1/SW2XE2	包装 (个) Packing
M10X1.0	HSM-P-M10	4.0-6.5	5.0	14X15.5	50
M16X1.5	HSM-P-M16	4.0-6.5 5.0-8.0 6.5-9.5	6.0	19X21 / 17X18.9	50
M20X1.5	HSM-P-M20	4.0-6.5 5.0-8.0 6.5-9.5 7.0-10.5	6.0	22X24.4	50
M20X1.5	HSM-P-M20	4.0-6.5 5.0-8.0 6.5-9.5 7.0-10.5 9.0-13.0	6.5	22X24.4	50
M25X1.5	HSM-P-M25	4.0-6.5 5.0-8.0 6.5-9.5 7.0-10.5 9.0-13.0 11.5-15.5	6.5	27X30.4 / 24X26.7	25
M32X1.5	HSM-P-M32	7.0-10.5 9.0-13.0 11.5-15.5 14.0-18.0 17.0-20.5	7.0	36X39.6 / 30X33.5	20
M40X1.5	HSM-P-M40	11.5-15.5 14.0-18.0 17.0-20.5 20.0-25.0 24.0-28.0	8.0	46X51 / 41X45	20
M50X1.5	HSM-P-M50	27.0-32.0 29.0-34.0 32.0-36.0	9.0	55X60.5 / 50X53.5	10
M50X1.5	HSM-P-M50	36.0-40.0	10.0	60X64.5	10
M63X1.5	HSM-P-M63	39.0-44.0	10.0	68X74 / 64X69	5