

## RL 金属外螺纹 90 度弯接头

### RL 90° Elbow fitting with metal external thread

材质：尼龙 66，黄铜镀镍螺纹

Material: Polyamide 66, Nickel plated brass thread

颜色：黑色 / 灰色

Colour: Black(BL) /Grey(GR)

温度：-45°C~+120°C，短时间 150°C

Temperature range: -45°C ~ +120°C, short-term to 150°C

防护等级：IP66, IP68(与软管及 RLS 密封垫配合使用)

Protection Degree: IP66, IP68(For use with conduits & RLS seal)

特性：自熄灭性好，不含卤素，磷，镉，同时具有极好的抗冲击强度

Properties: Self-extinguishing, free of halogen, phosphor and cadmium, with excellent impact strength.

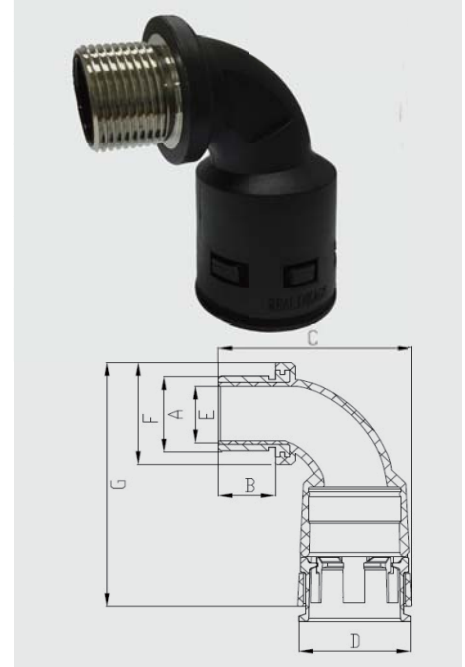

CE  UL测试 EN45545

已通过铁道客车 67 号文件测试

#### M 螺纹

适配软管尺寸 Fits to Conduit size	型号 Part no.	铁路专属型号① Special no.	螺纹 A Thread	B	C	D	E	F	G	包装(个) Packing
13	RL13-M16-CS90	DKPA66-10-M16x1.5-CS90	M16X1.5	11.5	40.6	20.0	10.7	22.0	59.8	50
16	RL16-M16-CS90	DKPA66-12-M16x1.5-CS90	M16X1.5	11.5	41.4	22.0	10.7	22.0	61.5	50
21	RL21-M20-CS90	DKPA66-17-M20x1.5-CS90	M20X1.5	14.0	48.1	28.5	14.5	27.0	66.1	50
28	RL28-M25-CS90	DKPA66-23-M25x1.5-CS90	M25X1.5	16.0	58.8	37.0	19.0	35.0	77.7	20
34	RL34-M32-CS90	DKPA66-29-M32x1.5-CS90	M32X1.5	16.0	68.8	43.5	25.5	42.0	90.4	20
42	RL42-M40-CS90	DKPA66-36-M40x1.5-CS90	M40X1.5	16.0	85.5	53.0	31.7	53.0	114.0	10
54	RL54-M50-CS90	DKPA66-48-M50x1.5-CS90	M50X1.5	16.0	98.0	66.0	41.2	66.0	130.0	5
54	RL54-M63-CS90	DKPA66-48-M63x1.5-CS90	M63X1.5	16.0	98.0	66.0	47.0	73.0	133.5	5

#### PG 螺纹

适配软管尺寸 Fits to Conduit size	型号 Part no.	铁路专属型号① Special no.	螺纹 A Thread	B	C	D	E	F	G	包装(个) Packing
13	RL13-PG9-CS90	DKPA66-10-PG9-CS90	PG9	12.0	40.1	20.0	8.0	22.0	59.8	50
16	RL16-PG11-CS90	DKPA66-12-PG9-CS90	PG11	12.0	40.9	22.0	12.5	22.0	61.5	50
21	RL21-PG13-CS90	DKPA66-17-PG13-CS90	PG13.5	13.0	45.6	28.5	15.5	28.0	66.6	50
21	RL21-PG16-CS90	DKPA66-17-PG16-CS90	PG16	13.0	45.6	28.5	17.7	30.0	67.6	50
28	RL28-PG21-CS90	DKPA66-23-PG21-CS90	PG21	14.0	55.8	37.0	22.3	38.0	78.0	20
34	RL34-PG29-CS90	DKPA66-29-PG34-CS90	PG29	14.0	65.8	43.5	30.0	45.0	91.9	20
42	RL42-PG36-CS90	DKPA66-36-PG36-CS90	PG36	17.0	83.5	53.0	38.0	59.0	117.0	10
54	RL54-PG48-CS90	DKPA66-48-PG48-CS90	PG48	17.0	97.0	66.0	49.3	69.0	131.5	5

备注：铁路专属型号①为铁道客车，其他客车车辆，动车组及特种车辆专属型号。

Note: railway special model number is for railway passenger cars, other passenger vehicles, motor trains unit and special vehicle exclusive models